

DRAWING MADE IN AMERICAN PRODUCTION

© 1969 BY AMP INCORPORATED. ALL RIGHTS RESERVED. AMP PRODUCTS COVERED BY PATENTS AND/OR PATENT PENDING.

ALL DIMENSIONS UNLESS OTHERWISE SPECIFIED ARE IN INCHES. DIMENSIONS IN PARENTHESES ARE FOR INFORMATION ONLY AND ARE NOT TO BE USED FOR FABRICATION.

REVISIONS				
ZONE	LTR	DESCRIPTION	DATE	APPROVED
	E	MAT'L WAS B-10	11/22/72	Ken K
	F	REVISED NOTE 1	10-15-73	JPA
	G	REVISED PER ECN 4349	5-22-74	M.L.
	H	REV PER ECN 5-3960	9/16/87	R.S.
	J	OBS. 830177-2 ECN DF-0694 mc	9/13/88	J.W.

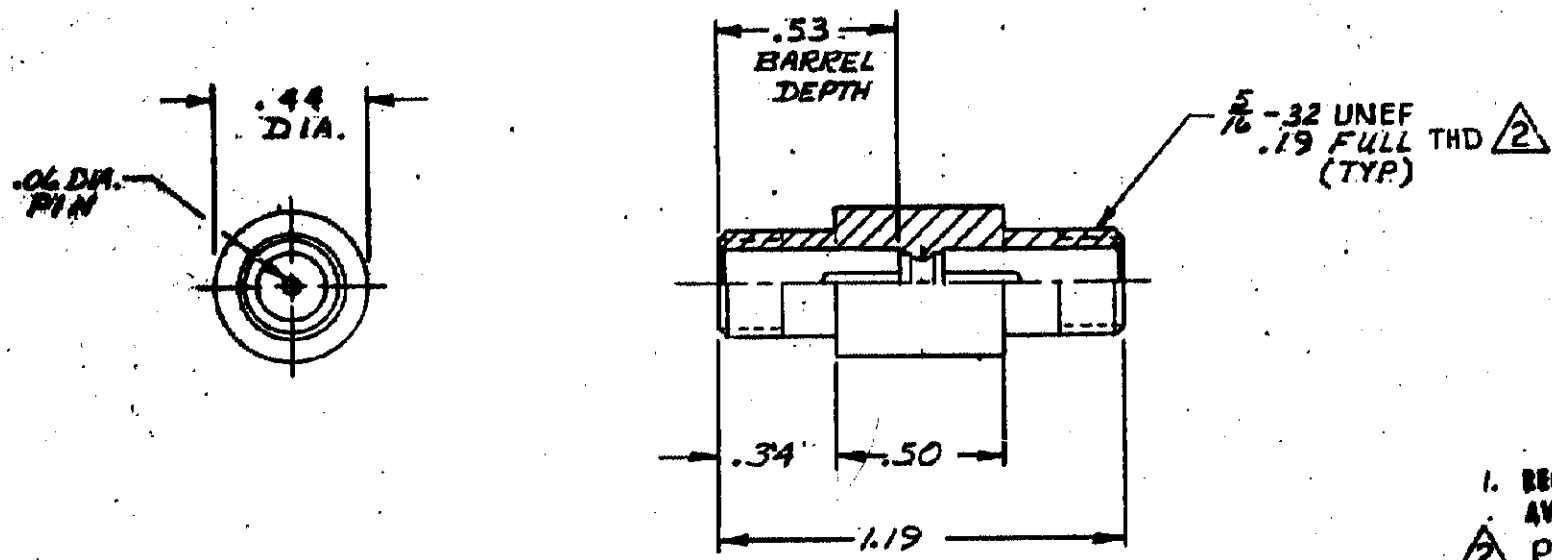

1. RECEPTACLE TO MATE WITH AMP LGN-1/2 LEAD ASSEMBLY. AVAILABLE SEPARATELY.
 2. PER FEDERAL STANDARD H-28 3 WIRE METHOD. DIMENSION OVER WIRES TO BE: .307-.315.

OBS	830177-2	AS SHOWN EXCEPT CONTACT (GOLD PLATED)
	830177-1	AS SHOWN EXCEPT CONTACT (TIN PLATED)

QTY REQD	QTY REQD	ITEM NO.	DWG SIZE	PART OR IDENTIFYING NO.	NOMENCLATURE OR DESCRIPTION	SYMBOL
-2	-1					

UNLESS OTHERWISE SPECIFIED DIMENSIONS ARE IN INCHES TOLERANCES .10-.04 ANGLES .000-.015				CONTRACT NO. DR 4-16-69		AMP INCORPORATED CAPTRON DIVISION ELIZABETHTOWN, PENNSYLVANIA	
MATERIAL: MOLDED GLASS EPOXY				CHK APP'D J.P. 11/16/69		NAME: RECEPTACLE, FEED-THRU FOR SPLICE APPLICATION LGN-1/2	
FINISH: BLACK				DSGN APP'D		SIZE: B	CODE IDENT NO.: 00779
NEXT ASSY				OTHER APP'D		NUMBER: 830177	
FINAL ASSY				SCALE: 1:1			
NEXT ASSY				SHEET 1 OF 1			
USED ON				CUSTOMER DRAWING			
APPLICATION				REVISION			

CUSTOMER DRAWING
 REVISION